

STEREOTECH

3

LOUDSPEAKER  
SYSTEM

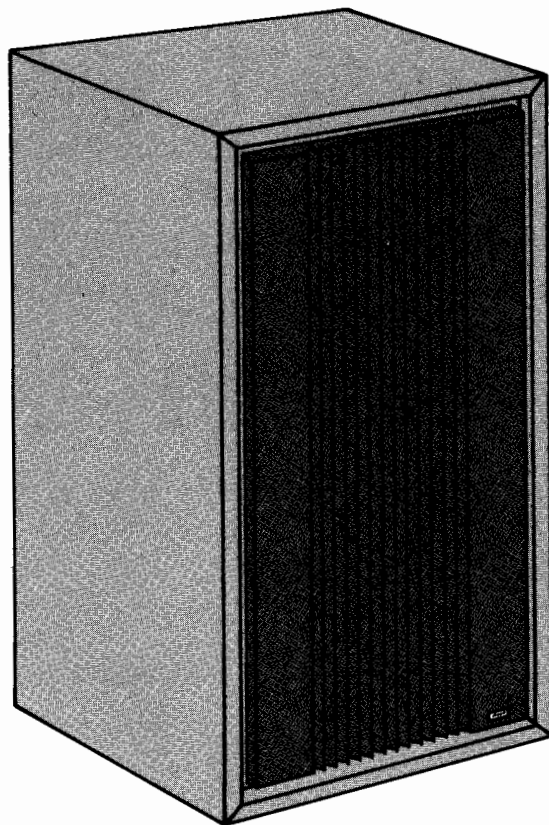

INSTRUCTION  
MANUAL

SERIAL NUMBER BP1001 AND ABOVE

# SPECIFICATIONS

## CABINET SIZE

26" high 15" wide 13-5/16" Deep

## CONSTRUCTION

45 pound density non-resonant particle board panels.  
Extra heavy 1 inch front panel. Heavy gauge 8 mil vinyl. Simulated walnut finish.

## SPEAKER SIZE

Woofer 12" dia. frame size (9-1/2" dia. radiator)  
Mid-range 5" dia. frame size (3-1/4" dia. radiator)  
Tweeter 1-3/4" dia. radiator

## CONTROLS

Mid-range 600Hz To 3500Hz - boost, normal, and cut  
Tweeter 3500Hz To 20,000Hz - boost, normal, and cut

## POWER HANDLING: Sine wave steady state

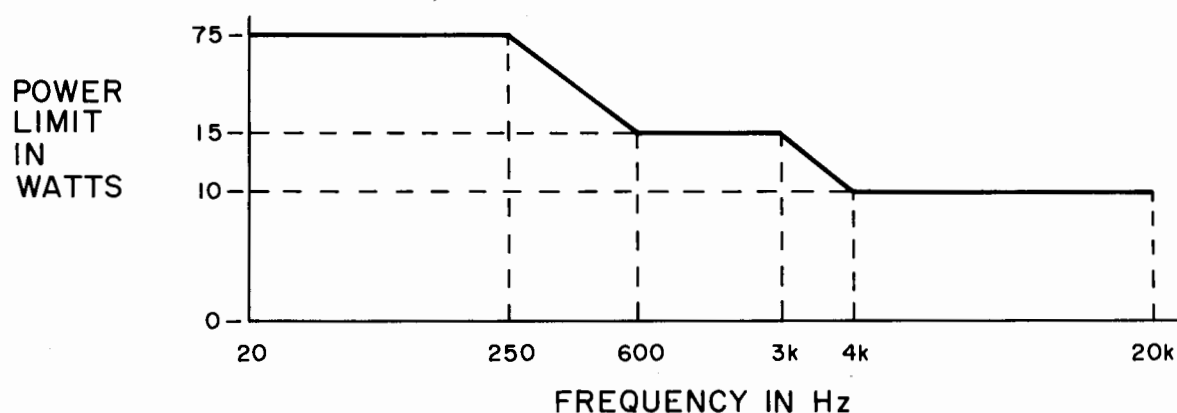

Avoid operating the speaker system with sustained sine wave signals at power levels greater than the indicated limits. Permanent damage may result.

## POWER HANDLING: Program Material

High energy peaks normal to orchestral music are easily and faithfully reproduced by the speaker system. These peaks are of relatively short duration and do not produce the heating effect caused by sustained tone operation. The Stereotech 3 speaker system will handle up to 100 watts of orchestral program material. Care must also be taken to use a power amplifier that has an adequate power rating. If a low power amplifier is used, the loudest passages may be "clipped" by the amplifier. This clipping will cause the speaker to sound distorted. The large harmonic content of a badly "clipped" signal can cause excessive heating and resulting damage to the high frequency speaker elements.

## OUTPUT LEVEL

At 1 meter in a non-reflecting environment, the system will nominally produce an 89dB sound pressure level when driven with 1 watt referred to 8 $\Omega$ .

## LISTENING QUALITY

Smooth response has been achieved by careful design under controlled laboratory conditions. The performance of the speakers in your listening room may be influenced to some degree by the room size, shape, construction, and furnishing. The location of the speakers in the room will also affect listening quality. The additional features of low distortion and wide dispersion will help to provide superior sound in a typical listening environment.

There are two controls at the rear of the system. They provide 2-3dB boost or cut in the frequency ranges stated in the specifications. For example, a room with heavy furnishings, drapes, books, and rugs will absorb some of the high frequencies. This may cause the speaker system to sound "dull". The tweeter control would then be placed in the "+" position to compensate. The controls may also be used to adjust for individual tastes in music.

## CONNECTIONS

Use heavy gauge wire (#18 AWG or larger) when connecting the speaker system to the power amplifier. The system leads preferably should have less than 0.4 ohms resistance and not more than 0.8 ohms resistance. (62 feet of #18 wire has 0.4 ohms resistance. This corresponds to 31 feet of two conductor wire).

Be sure to observe polarity when connecting the speaker system and power amplifier leads to maintain proper stereo perspective.

# SERVICE NOTES

1. Speaker element failure can be quickly located by using FM hiss at a low power level. Listen at each speaker to verify if all the speakers are at least working. A low power (1-5 watt) sine wave sweep 20-20kHz can be used as a quick check for distortion. A speaker element with obvious distortion must be replaced.
2. To determine if the speaker element is dead, remove the speaker and momentarily connect a 1-1/2 -6V battery across the terminals. If no sound is heard, the speaker element must be replaced.
3. The crossover network must be inspected when burned out speaker elements are replaced. The network must also be inspected if a speaker element produces sound with the battery test but does not play when connected in the system. The woofer must be removed to get to the crossover. Check for burned resistors, bad connections, broken wires, etc.
4. After soldering a replacement crossover element into the circuit, use RTV Silicone rubber adhesive to insure a vibration free bond to the board.
5. Use only Stereotech replacement capacitors. These have been specially selected for low ESR.
6. The colored wire (other than black) always goes to the red marked terminal on the speaker. This is the positive terminal. If the polarity of a speaker is unknown, momentarily connect a 1-1/2 - 6V battery to the terminals. When the cone moves away from the magnet, it means the + terminal of the battery is connected to the + terminal of the speaker.
7. When installing speakers or crossover network in the cabinet, care must be taken to insure a tight air seal to the cabinet. Replace the foam gasket if necessary. Mortite caulking compound or equivalent could be substituted but care must be taken that it will not be visible after the part is installed.
8. If the woofer screw strips out in the wood of the cabinet, the speaker can be rotated and new mounting holes drilled.
9. After the system is reassembled, it must be checked for air leaks. This can be done by putting a 20Hz sine wave into the system at 20 watts. By listening around the speakers closely for hissing sounds, areas can be located that must be sealed. The system must also be swept from 20Hz to 250Hz at 20 watts to insure there are no vibrations due to wires hitting the woofer cone, etc.
10. All defective parts must be packed well and returned to the Stereotech Division.

## SPEAKER LOCATION

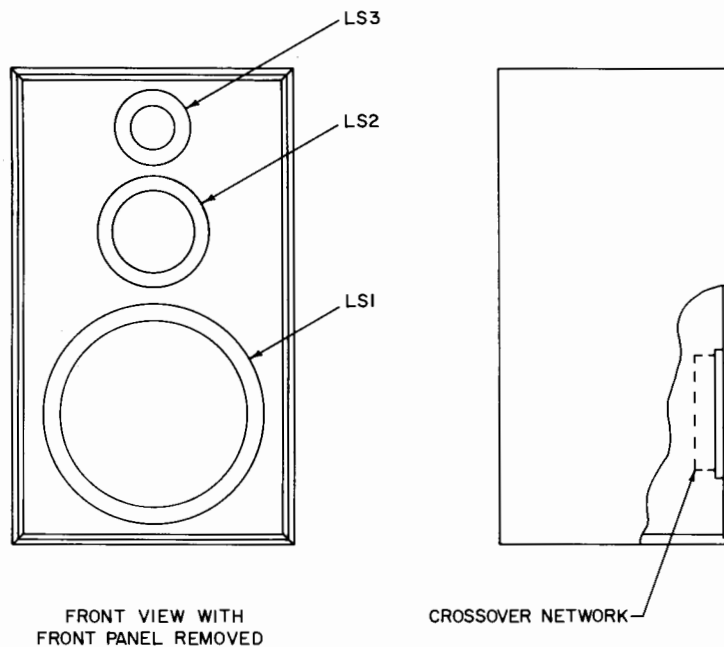

# CROSSOVER NETWORK

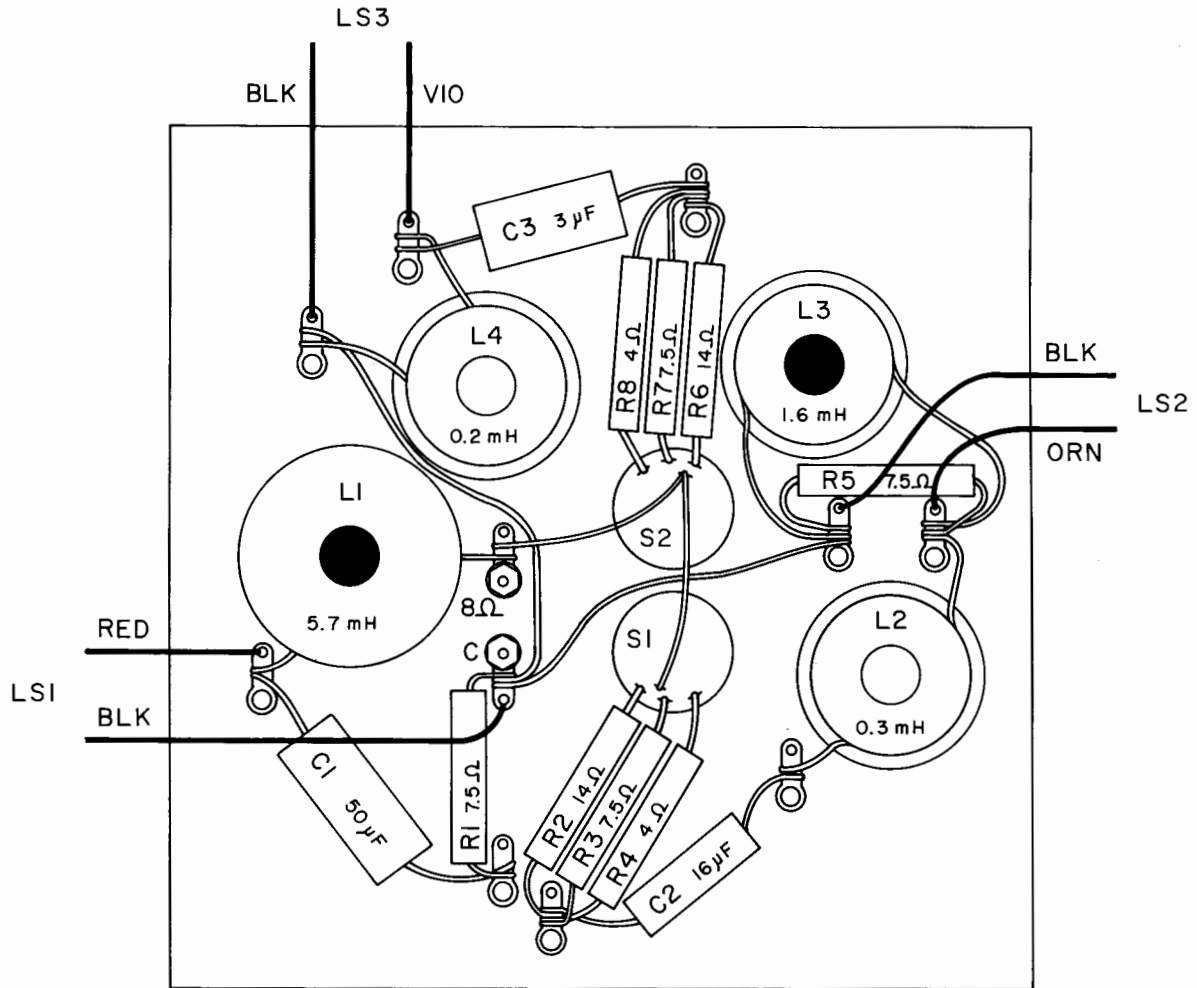

ASSEMBLY 044-711

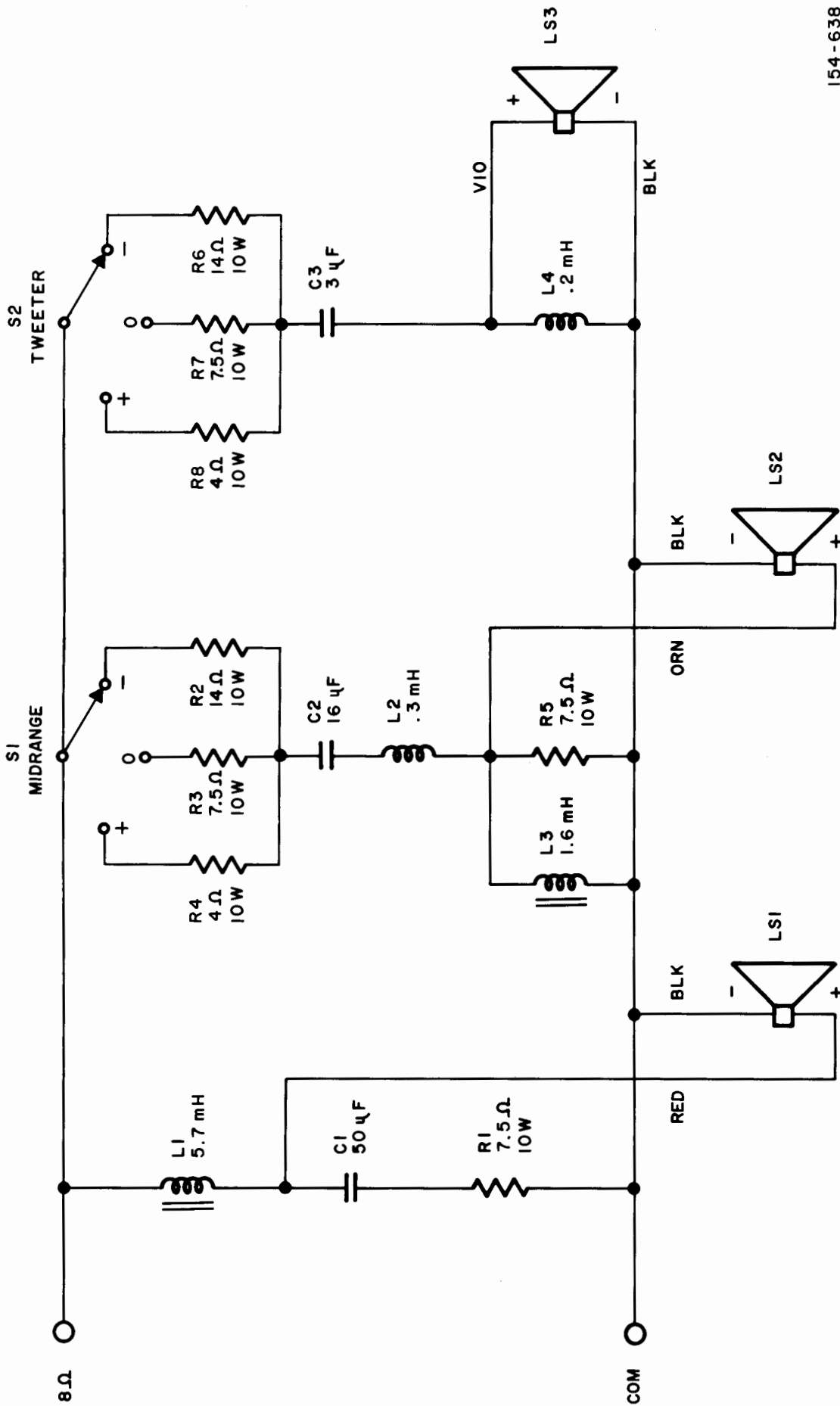

154-638

SYSTEM SCHEMATIC

# REPLACEMENT PARTS

Replacement parts may be obtained when ordered by PART NUMBER from:

Stereo Technology Division  
1010 Conklin Rd.  
R.D. #1 Box 413A  
Conklin, N. Y. 13748

## CAPACITORS

Symbol Number	Description	Part Number
C1	Elect 50 $\mu$ F 10% 100V	066-192
C2	Elect 16 $\mu$ F 10% 100V	066-224
C3	Mylar 3 $\mu$ F 10% 100V	064-121

## CHOKES

L1	Choke 5.7mH	122-157
L2	Choke 0.3mH 5%	122-159
L3	Choke 1.6mH 5%	122-162
L4	Choke 0.2mH 5%	122-158

## RESISTORS

R1,3,5,7	Wirewound 7.5 $\Omega$ 5% 10W	139-090
R2,6	Wirewound 14 $\Omega$ 10% 10W	139-111
R4,8	Wirewound 4 $\Omega$ 5% 10W	139-086

## LOUDSPEAKERS

LS1	12" Woofer	036-039
LS2	5" Midrange	036-040
LS3	4-1/4" Tweeter	036-042

## SWITCHES

S1	Mid Freq. Level	146-169
S2	Hi Freq. Level	146-169

## MISCELLANEOUS ITEMS

Terminal - Red	084-094
Terminal - Black	084-095
Shipping Carton	033-197
Polybag	033-202
Foam Front Panel Assy.	044-713
Knobs - Switch	094-144
Gasket: 12" woofer	094-092
Gasket: 5" midrange	094-095
Gasket; 4-1/4" tweeter	094-102
Gasket: Network	094-105

STEREO TECHNOLOGY DIVISION  
1010 CONKLIN RD.  
RD 1 BOX 413A  
CONKLIN, NEW YORK 13748